

FICHE TECHNIQUE PRODUIT

Cric hydraulique à patte « RMH »

Référence : RMH

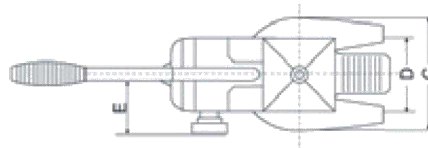
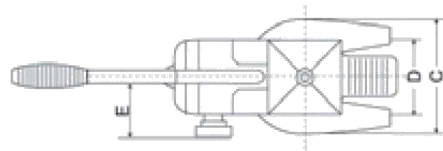
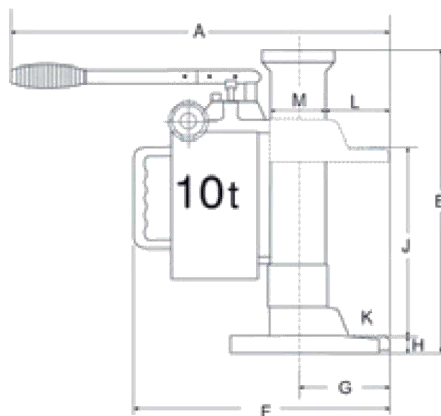
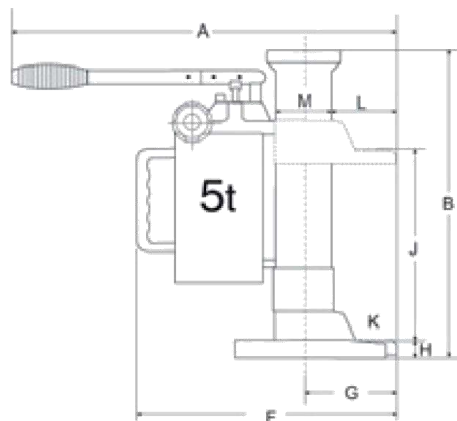

Caractéristiques techniques :

- Construction compacte et stable
- Cage rotatif 360°
- Vitesse de descente réglable
- Protégé contre les surcharges
- Levier démontable

| Référence | | RMH-50 | RMH-100 | RMH-250 |
|----------------|---------------------------|--------|---------|---------|
| CMU | kg | 5 000 | 10 000 | 25 000 |
| | Effort sur le levier max. | 38 | 40 | 40 |
| Poids unitaire | kg | 25 | 35 | 102 |

| Référence | | RMH-50 | RMH-100 | RMH-250 |
|-----------|----|---------|---------|-----------|
| A | mm | 740 | 745 | 1305/1225 |
| B | mm | 368/573 | 420/650 | 505/720 |
| C | mm | 190 | 190 | 283 |
| D | mm | 93 | 108 | 175 |
| E | mm | 98 | 98 | - |
| F | mm | 275 | 280 | 459 |
| G | mm | 115 | 120 | 420 |
| H | mm | 25/230 | 30/260 | 58/273 |
| J | mm | 205 | 230 | 215 |
| K | mm | 53 | 55 | 90 |
| L | mm | 77 | 74,5 | 142,5 |
| M | mm | 76 | 91 | 155 |
| N | mm | - | - | 70 |

